

# Answers

## Chapter 1

### Worksheet 1

- 95,530
- 28,614
- 70,451
- 68,973
- twenty-seven thousand, four hundred ninety-five
- forty-eight thousand, two hundred thirty
- eighty-four thousand
- ninety thousand, six hundred five
- 52,800
- 83,640
- 29,351
- 60,284
- 36,516
- 70,014
- 80,000 90,000 100,000
- 19,030 19,040 19,050
- 30,700 30,800 30,900
- 70,800 80,900 91,000
- 7, 2, 8, 4, 5
- 2, 4, 3, 1, 9
- 3, 5, 0
- 9, 1, 6
- tens
- hundreds
- thousands
- ten thousands
- 90
- 90,000
- 900
- 9
- 98,653
- 78,423
- ten thousands
- 8
- thousands, 6,000
- 10
- $42,859 = 40,000 + \underline{2,000} + 800 + \underline{50} + 9$
- $61,734 = \underline{60,000} + 1,000 + \underline{700} + 30 + \underline{4}$
- $24,570 = \underline{20,000} + \underline{4,000} + \underline{500} + \underline{70}$
- $68,037 = \underline{60,000} + \underline{8,000} + \underline{0} + \underline{30} + \underline{7}$
- 84,796 85,796  
Rule: Add 1,000.
- 34,400 24,400  
Rule: Subtract 10,000.
- 35,180 34,175  
Rule: Subtract 1,005.

### Worksheet 2

– 5,000; + 5,000

- 75,000
- 65,000

- 45,000
- 35,000
- >
- <
- 37,482 52,104 58,369
- 79,780
- 4,000
- 95,325
- 40,400
- 52,700 47,700  
Rule: Subtract 5,000.
- 58,578 64,778  
Rule: Add 3,100.
- 17,440 17,080  
Rule: Subtract 120.

### Worksheet 3

- a. 12; 1; 2  
c. 14; 1; 4; 14
- a. 11; 1; 1  
c. 11; 1; 1; 110
- a. 12; 1; 2  
c. 11; 1; 1; 1,100
- a. 4,979  
c. 7,988
- a. 7,690  
c. 8,527
- a. 5; 5
- a. 4; 4    b. 8; 8    c. 5; 5    d. 7; 7
- a. 2; 2; 3; 23  
b. 4; 8; 4; 2; 42  
c. 3; 6; 3; 4; 340  
d. 1; 10; 5; 1; 5; 1,500  
e. 5; 10; 7; 5; 3; 530  
f. 6; 10; 9; 6; 1; 6,100
- a. 4,531  
c. 777  
e. 3,525  
g. 26,666  
i. 15,315
- b. 13; 1; 3; 13  
d. 15; 1; 5; 15
- b. 16; 1; 6; 160  
d. 12; 1; 2; 120
- b. 14; 1; 4; 1,400  
d. 10; 1; 0; 1,000
- b. 8,799  
d. 9,889
- b. 5,835  
d. 8,163
- b. 5; 5

## Chapter 2

### Worksheet 1

- 742; 500; 200; 700; 700; Yes
- 349; 800; 500; 300; 300; Yes
- 7,181; 5,000; 2,000; 7,000; Yes
- 5,621; 15,000; 9,000; 6,000; Yes
- $3,000 + 1,000 = 4,000$

6.  $9,000 - 2,000 = 7,000$
7.  $333; 700 - 400 = 300$ ; 333 is close to 300, so the answer is reasonable.
8.  $5,965; 2,000 + 3,000 = 5,000$ ; 5,965 is close to 5,000, so the answer is reasonable.
9.  $2,731; 5,000 - 2,000 = 3,000$ ; 2,731 is close to 3,000, so the answer is reasonable.
10. 978; 326;  $300 \times 3 = 900$ ; Yes
11. 534; 267;  $300 \times 2 = 600$ ; Yes
12. 216;  $50 \times 4 = 200$ ; 216 is close to 200, so the answer is reasonable.
13. 336;  $100 \times 3 = 300$ ; 336 is close to 300, so the answer is reasonable.
14.  $496 \div 4 = \underline{124}$   
 $4 \times \underline{120} = \underline{480}$   
 $4 \times \underline{130} = \underline{520}$   
 $\underline{480} \div 4 = \underline{120}$   
 The answer is reasonable.
15.  $516 \div 2 = \underline{258}$   
 $\underline{2} \times \underline{250} = \underline{500}$   
 $\underline{2} \times \underline{260} = \underline{520}$   
 $\underline{520} \div \underline{2} = \underline{260}$   
 The answer is reasonable.
16.  $780 \div 5 = \underline{156}$   
 $\underline{5} \times \underline{150} = \underline{750}$   
 $\underline{5} \times \underline{160} = \underline{800}$   
 $\underline{800} \div \underline{5} = \underline{160}$   
 The answer is reasonable.
17. An exact answer is needed.  
 $\$111 - \$52 - \$33 - \$21 = \$5$  left  
 Ms. Katy has enough money to buy all these things. She will have \$5 left.
18. An exact answer is needed.  
 $784 \text{ mL} - 309 \text{ mL} = 475 \text{ mL}$   
 They drink 475 milliliters of milk in the afternoon.
19. An estimate is needed.  
 $\$14.99$  is about \$15.  
 $\$5.29 \times 2$  is about  $\$5 \times 2 = \$10$ .  
 $\$8.99$  is about \$9.  
 $\$15 + \$10 + \$9 = \$34$   
 Caithlin spent about \$34 in all.

## Worksheet 2

1. 105; 105, 5      2. 105; 105, 35, 3
3. 96; 96; 8, 12, 96      4. 104; 104; 26, 4, 104
5. 2 R 4; No; No      6. 3; Yes; Yes

7. 4; Yes; Yes
8.  $24 = 1 \times 24$   
 $= 2 \times \underline{12}$   
 $= \underline{3} \times \underline{8}$   
 $= \underline{4} \times \underline{6}$   
 The factors of 24 are 1, 2, 3, 4, 6, 8, 12, and 24.
9.  $54 = \underline{1} \times \underline{54}$   
 $= \underline{2} \times \underline{27}$   
 $= \underline{3} \times \underline{18}$   
 $= \underline{6} \times \underline{9}$   
 The factors of 54 are 1, 2, 3, 6, 9, 18, 27, and 54.
10.  $72 = \underline{1} \times \underline{72}$   
 $= \underline{2} \times \underline{36}$   
 $= \underline{3} \times \underline{24}$   
 $= \underline{4} \times \underline{18}$   
 $= \underline{6} \times \underline{12}$   
 $= \underline{8} \times \underline{9}$   
 The factors of 72 are 1, 2, 3, 4, 6, 8, 9, 12, 18, 24, 36, and 72.
11.  $108 = \underline{1} \times \underline{108}$   
 $= \underline{2} \times \underline{54}$   
 $= \underline{3} \times \underline{36}$   
 $= \underline{4} \times \underline{27}$   
 $= \underline{6} \times \underline{18}$   
 $= \underline{9} \times \underline{12}$   
 The factors of 108 are 1, 2, 3, 4, 6, 9, 12, 18, 27, 36, 54, 108.
12. 16; 17 R 1; No      13. 14; 19; Yes
14. 5 R 5; 12; No
15. 21: ①, 3, ⑦, 21  
 28: ①, 2, 4, ⑦, 14, 28  
 The greatest common factor is 7.
16. 32: ①, ②, 4, 8, 16, 32  
 42: ①, ②, 3, 6, 7, 14, 21, 42  
 The greatest common factor is 2.
17. 48: ①, ②, ③, ④, ⑥, ⑧, ⑫, 16, ⑳, 48  
 72: ①, ②, ③, ④, ⑥, ⑧, 9, ⑫, 18, ⑳, 36, 72  
 The greatest common factor is 24.
18. 
$$\begin{array}{r|l} 2 & 12, 24 \\ 2 & \underline{6, 12} \\ 3 & \underline{3, 6} \\ & 1, 2 \end{array}$$
  
 $\underline{2} \times \underline{2} \times \underline{3} = \underline{12}$   
 The greatest common factor is 12.

$$19. \begin{array}{r} 2 \overline{) 36, 42} \\ 3 \overline{) 18, 21} \\ \hline 6, 7 \end{array}$$

$$2 \times 3 = 6$$

The greatest common factor is 6.

$$20. \begin{array}{r} 2 \overline{) 54, 72} \\ 3 \overline{) 27, 36} \\ 3 \overline{) 9, 12} \\ \hline 3, 4 \end{array}$$

$$2 \times 3 \times 3 = 18$$

The greatest common factor is 18.

$$21. \begin{array}{r} 3 \overline{) 15, 42} \\ \hline 5, 14 \end{array}$$

The greatest common factor is 3.

$$22. 15, 24, 36, 54, \text{ and } 75$$

$$23. 10, 15 \text{ and } 75 \quad 24. 15 \text{ and } 75$$

$$25. 5 = 1 \times 5$$

The factors of 5 are 1 and 5.

So, 5 is a prime number.

$$26. 9 = 1 \times 9$$

$$= 3 \times 3$$

The factors of 9 are 1, 3, and 9.

So, 9 is not a prime number.

$$27. 11 = 1 \times 11$$

The factors of 11 are 1 and 11.

So, 11 is a prime number.

$$28. 26 = 1 \times 26$$

$$= 2 \times 13$$

The factors of 26 are 1, 2, 13, and 26.

So, 26 is not a prime number.

$$29. 20 = 1 \times 20$$

$$= 2 \times 10$$

$$= 4 \times 5$$

The factors of 20 are 1, 2, 4, 5, 10, and 20.

So, 20 is a composite number.

$$30. 13 = 1 \times 13$$

The factors of 13 are 1 and 13.

So, 13 is not a composite number.

$$31. 63 = 1 \times 63$$

$$= 3 \times 21$$

$$= 7 \times 9$$

The factors of 63 are 1, 3, 7, 9, 21, and 63.

So, 63 is a composite number.

$$32. 41 = 1 \times 41$$

The factors of 41 are 1 and 41.

So, 41 is not a composite number.

$$33. 13, 41$$

34. A prime number has only 2 different factors.

13 has only 2 different factors, 1 and 13.

So, 13 is a prime number. 41 has only 2 different factors, 1 and 41. So, 41 is a prime number.

### Worksheet 3

$$1. 6; 12; 18; 24; 30; 36; 42; 48$$

6, 12, 18, 24, 30, 36, 42, and 48

$$2. 8; 16; 24; 32; 40; 48; 56; 64$$

8, 16, 24, 32, 40, 48, 56, and 64

$$3. 23$$

$$4. 51$$

$$5. 17, 27$$

$$6. 39, 47, 49, 79$$

$$7.$$

$$\begin{array}{r} 8 \\ 3 \overline{) 24} \\ \underline{24} \\ 0 \end{array}$$

Yes, 24 is the eighth multiple of 3.

$$8.$$

$$\begin{array}{r} 7 \\ 6 \overline{) 45} \\ \underline{42} \\ 3 \end{array}$$

No, 45 is not a multiple of 6. It cannot be divided exactly by 6.

$$9.$$

$$\begin{array}{r} 12 \\ 8 \overline{) 96} \\ \underline{80} \\ 16 \\ \underline{16} \\ 0 \end{array}$$

Yes, 96 is the twelfth multiple of 8.

$$10. 35; 35$$

$$11. 24, 48; 24$$

$$12. 2: 2, 4, 6, 8, \textcircled{10}, 12, 14, 16, 18, \textcircled{20}$$

$$5: 5, \textcircled{10}, 15, \textcircled{20}$$

The least common multiple is 10.

$$13. 6: 6, 12, \textcircled{18}, 24, 30, \textcircled{36}$$

$$9: 9, \textcircled{18}, 27, \textcircled{36}, 42$$

The least common multiple is 18.

$$14. \begin{array}{r} 3 \overline{) 9, 18} \\ 3 \overline{) 3, 6} \\ \hline 1, 2 \end{array}$$

$$3 \times 3 \times 1 \times 2 = 18$$

15. 
$$\begin{array}{r} 2 \overline{) 14, 28} \\ 7 \overline{) 7, 14} \\ 1, 2 \end{array}$$

$$2 \times 7 \times 1 \times 2 = 28$$

16. 
$$\begin{array}{r} 3 \overline{) 15, 45} \\ 5 \overline{) 5, 15} \\ 1, 3 \end{array}$$

$$3 \times 5 \times 1 \times 3 = 45$$

17. 
$$\begin{array}{r} 2 \overline{) 12, 52} \\ 2 \overline{) 6, 26} \\ 3, 13 \end{array}$$

$$2 \times 2 \times 3 \times 13 = 156$$

### Worksheet 4

1. a.  $14 \times 3$     b.  $13 \times 5$     c.  $12 \times 7$

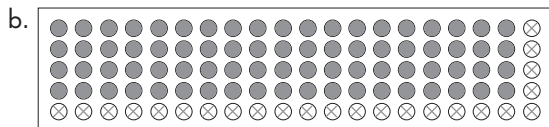
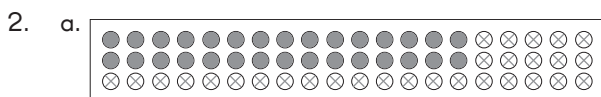

3. a. 13; 8; 10; 8; 3; 80; 24; 104  
 b. 18; 9; 10; 9; 8; 90; 72; 162
4. a. 10; 70; 4; 28; 70; 28; 98  
 b. 5; 50; 5; 40; 50; 40; 90  
 c. 10; 20; 2; 12; 20; 12; 32  
 d. 6; 60; 5; 30; 60; 30; 90
5. a. 6; 10; 6; 3; 60; 18; 78  
 b. 4; 20; 4; 3; 80; 12; 92  
 c. 5; 30; 5; 7; 150; 35; 185
6. a. 126    b. 216    c. 210    d. 235    e. 232

## Chapter 3

### Worksheet 1

1. 8                                  2. 2, 8
3. 48, 4, 8                        4. 20, 2
5. 42, 4, 2                        6. 18, 1, 8
7. 28, 2, 8                        8. 48, 4, 8
9. 40, 4
10. 6; 9; 18, 8; 16; 16,896

$$\begin{array}{r} 1 \\ 5, 6 3 2 \\ \times \quad \quad 3 \\ \hline 1 6, 8 9 6 \end{array}$$

11. 5; 5; 5; 9; 4; 25; 25, 4, 29,095

$$\begin{array}{r} 4 \quad 4 \\ 5, 8 1 9 \\ \times \quad \quad 5 \\ \hline 2 9, 0 9 5 \end{array}$$

12. 0; 8; 28, 2, 8; 32; 32, 2, 34; 34,880

$$\begin{array}{r} 2 \\ 8, 7 2 0 \\ \times \quad \quad 4 \\ \hline 3 4, 8 8 0 \end{array}$$

13. 54, 5, 4; 0; 0, 5, 5; 30, 3; 36; 36, 3, 39;  
 39,054

$$\begin{array}{r} 3 \quad 5 \\ 6, 5 0 9 \\ \times \quad \quad 6 \\ \hline 3 9, 0 5 4 \end{array}$$

14. 56, 5, 6; 42; 42, 5, 47, 4, 7; 49; 49, 53, 5,  
 3; 28; 28, 5, 33; 33,376

$$\begin{array}{r} 5 \quad 4 \quad 5 \\ 4, 7 6 8 \\ \times \quad \quad 7 \\ \hline 3 3, 3 7 6 \end{array}$$

15. 
$$\begin{array}{r} 1 \\ 7, 6 4 3 \\ \times \quad \quad 2 \\ \hline 1 5, 2 8 6 \end{array}$$

16. 
$$\begin{array}{r} 7 \quad 1 \quad 2 \\ 6, 9 2 3 \\ \times \quad \quad 8 \\ \hline 5 5, 3 8 4 \end{array}$$

17. 
$$\begin{array}{r} 5, 3 4 7 \\ \times \quad \quad 3 \\ \hline 2 1 \rightarrow \\ 1 2 0 \rightarrow \\ 9 0 0 \rightarrow \\ 1 5, 0 0 0 \rightarrow \\ 1 6, 0 4 1 \end{array}$$

18. 
$$\begin{array}{r} 4, 8 3 5 \\ \times \quad \quad 7 \\ \hline 3 5 \rightarrow \\ 2 1 0 \rightarrow \\ 5, 6 0 0 \rightarrow \\ 2 8, 0 0 0 \rightarrow \\ 3 3, 8 4 5 \end{array}$$

19. 
$$\begin{array}{r} 7 0 0 \\ \times \quad \quad 8 \\ \hline 5, 6 0 0 \end{array}$$

21. 
$$\begin{array}{r} 2 \quad 1 \\ 4, 7 2 6 \\ \times \quad \quad 3 \\ \hline 1 4, 1 7 8 \end{array}$$

$$\begin{array}{r} 7 \times 3 = 21 \\ 40 \times 3 = 120 \\ 300 \times 3 = 900 \\ 5,000 \times 3 = 15,000 \end{array}$$

$$\begin{array}{r} 5 \times 7 = 35 \\ 30 \times 7 = 210 \\ 800 \times 7 = 5,600 \\ 4,000 \times 7 = 28,000 \end{array}$$

20. 
$$\begin{array}{r} 1 \quad 3 \\ 9 2 8 \\ \times \quad \quad 4 \\ \hline 3, 7 1 2 \end{array}$$

22. 
$$\begin{array}{r} 1 \\ 9, 2 1 0 \\ \times \quad \quad 6 \\ \hline 5 5, 2 6 0 \end{array}$$

## Worksheet 2

1. 12
2. 230
3. 8
4. 600
5. 21
6. 1,500
7. 8; 48; 480
8. 3; 48; 480
9. 105; 1,050
10. 204; 2,040
11. 25; 2,500
12. 3, 33; 3,300

13. 7, 10; 42; 420
14. 74, 9, 10; 666, 10; 6,660
15. 42, 2; 4,200, 2; 8,400
16. 973, 100; 2,919, 100; 291,900

$$\begin{array}{r}
 17. \quad \begin{array}{r} 92 \\ \times 43 \\ \hline 1276 \\ 3680 \\ \hline 3956 \end{array}
 \end{array}$$

$$\begin{array}{r}
 18. \quad \begin{array}{r} 3436 \\ \times 57 \\ \hline 252 \\ 1800 \\ \hline 2052 \end{array}
 \end{array}$$

$$\begin{array}{r}
 19. \quad \begin{array}{r} 11 \\ 240 \\ \times 33 \\ \hline 720 \\ 7200 \\ \hline 7920 \end{array}
 \end{array}$$

$$\begin{array}{r}
 20. \quad \begin{array}{r} 47 \\ 508 \\ \times 69 \\ \hline 4572 \\ 30480 \\ \hline 35052 \end{array}
 \end{array}$$

$$\begin{array}{r}
 21. \quad \begin{array}{r} 900 \\ \times 81 \\ \hline 900 \\ 72000 \\ \hline 72900 \end{array}
 \end{array}$$

$$\begin{array}{r}
 22. \quad \begin{array}{r} 24 \\ 13 \\ 637 \\ \times 75 \\ \hline 3185 \\ 44590 \\ \hline 47775 \end{array}
 \end{array}$$

23.  $\underline{70} \times \underline{50} = \underline{3,500}$   
 $68 \times 52$  is about 3,500.

24.  $\underline{40} \times \underline{70} = \underline{2,800}$   
 $42 \times 73$  is about 2,800.

25.  $\underline{200} \times \underline{80} = \underline{16,000}$   
 $239 \times 77$  is about 16,000.

26.  $\underline{1,000} \times \underline{40} = \underline{40,000}$   
 $984 \times 36$  is about 40,000.

27.  $1,566; 60 \times 30 = 1,800$   
 $1,566$  is close to  $1,800$ , so the answer is reasonable.

$$\begin{array}{r}
 1558 \\ \times 27 \\ \hline 406 \\ 1160 \\ \hline 1566 \end{array}$$

28.  $4,725; 60 \times 80 = 4,800$   
 $4,725$  is close to  $4,800$ , so the answer is reasonable.

$$\begin{array}{r}
 2163 \\ \times 75 \\ \hline 315 \\ 4410 \\ \hline 4725 \end{array}$$

29.  $4,658; 140 \times 30 = 4,200$ ; reasonable

$$\begin{array}{r}
 12137 \\ \times 34 \\ \hline 548 \\ 4110 \\ \hline 4658 \end{array}$$

30.  $63,080; 800 \times 80 = 64,000$ ; reasonable

$$\begin{array}{r}
 41760 \\ \times 83 \\ \hline 12280 \\ 60800 \\ \hline 63080 \end{array}$$

31.  $79,734; 800 \times 100 = 80,000$ ; reasonable

$$\begin{array}{r}
 11822 \\ \times 97 \\ \hline 151754 \\ 73980 \\ \hline 79734 \end{array}$$

32.  $38,315; 500 \times 80 = 40,000$ ; reasonable

$$\begin{array}{r}
 537485 \\ \times 79 \\ \hline 141365 \\ 33950 \\ \hline 38315 \end{array}$$

## Worksheet 3

1. 8, 1, 3; 3, 30; 30, 6

$$\begin{array}{r}
 116 \\ 5 \overline{) 580} \\ \hline 500 \\ \hline 80 \\ 50 \\ \hline 30 \\ 30 \\ \hline 0 \end{array}$$

2. 2, 1; 1, 10; 10, 16, 16, 4; 2

$$\begin{array}{r} 242 \\ 4 \overline{)968} \\ \underline{800} \\ 168 \\ \underline{160} \\ 8 \\ \underline{8} \\ 0 \end{array}$$

3.  $\begin{array}{r} 1 \\ 6 \overline{)858} \\ \underline{600} \\ 2 \end{array} \rightarrow \begin{array}{r} 1 \\ 6 \overline{)858} \\ \underline{600} \\ 258 \end{array} \rightarrow \begin{array}{r} 14 \\ 6 \overline{)858} \\ \underline{600} \\ 258 \\ \underline{240} \\ 1 \end{array}$

$\begin{array}{r} 143 \\ 6 \overline{)858} \\ \underline{600} \\ 258 \\ \underline{240} \\ 18 \\ \underline{18} \\ 0 \end{array} \leftarrow \begin{array}{r} 14 \\ 6 \overline{)858} \\ \underline{600} \\ 258 \\ \underline{240} \\ 18 \end{array} \leftarrow$

4.  $\begin{array}{r} 85 \\ 9 \overline{)765} \\ \underline{720} \\ 45 \\ \underline{45} \\ 0 \end{array}$

5.  $\begin{array}{r} 59 \\ 8 \overline{)472} \\ \underline{400} \\ 72 \\ \underline{72} \\ 0 \end{array}$

6.  $\begin{array}{r} 129 \\ 7 \overline{)903} \\ \underline{700} \\ 203 \\ \underline{140} \\ 63 \\ \underline{63} \\ 0 \end{array}$

7.  $\begin{array}{r} 139 \\ 5 \overline{)695} \\ \underline{500} \\ 195 \\ \underline{150} \\ 45 \\ \underline{45} \\ 0 \end{array}$

8.  $\begin{array}{r} 289 \\ 2 \overline{)578} \\ \underline{400} \\ 178 \\ \underline{160} \\ 18 \\ \underline{18} \\ 0 \end{array}$

9.  $\begin{array}{r} 289 \\ 3 \overline{)867} \\ \underline{600} \\ 267 \\ \underline{240} \\ 27 \\ \underline{27} \\ 0 \end{array}$

10.  $\begin{array}{r} 164 \\ 6 \overline{)984} \\ \underline{600} \\ 384 \\ \underline{360} \\ 24 \\ \underline{24} \\ 0 \end{array}$

11.  $\begin{array}{r} 168 \\ 4 \overline{)672} \\ \underline{400} \\ 272 \\ \underline{240} \\ 32 \\ \underline{32} \\ 0 \end{array}$

**Worksheet 4**

1.  $\begin{array}{r} 1,173 \\ 4 \overline{)4,692} \\ \underline{4,000} \\ 692 \\ \underline{400} \\ 292 \\ \underline{280} \\ 12 \\ \underline{12} \\ 0 \end{array}$

2.  $\begin{array}{r} 814 \\ 9 \overline{)7,326} \\ \underline{7,200} \\ 126 \\ \underline{90} \\ 36 \\ \underline{36} \\ 0 \end{array}$

3.  $\begin{array}{r} 631 \text{ R } 8 \\ 9 \overline{)5,687} \\ \underline{5,400} \\ 287 \\ \underline{270} \\ 17 \\ \underline{9} \\ 8 \end{array}$

4.  $\begin{array}{r} 1,342 \text{ R } 1 \\ 7 \overline{)9,395} \\ \underline{7,000} \\ 2,395 \\ \underline{2,100} \\ 295 \\ \underline{280} \\ 15 \\ \underline{14} \\ 1 \end{array}$

5.  $110 \times 6 = \underline{660}$      $120 \times 6 = \underline{720}$   
 680 is closer to 660 than to 720.  
 So,  $680 \div 6$  is about  $\underline{660} \div 6 = \underline{110}$ .
6.  $800 \times \underline{8} = \underline{6,400}$      $900 \times \underline{8} = \underline{7,200}$   
 6,882 is closer to 7,200 than to 6,400.  
 So,  $6,882 \div 8$  is about  $\underline{7,200} \div 8 = \underline{900}$ .

8. 7,500, 1,500; 1,500, reasonable

$$\begin{array}{r} 1,473 \text{ R } 4 \\ 5 \overline{) 7,369} \\ \underline{5,000} \\ 2,369 \\ \underline{2,000} \\ 369 \\ \underline{350} \\ 19 \\ \underline{15} \\ 4 \end{array}$$

9. 6,400, 800; 800, reasonable

$$\begin{array}{r} 843 \text{ R } 6 \\ 8 \overline{) 6,750} \\ \underline{6,400} \\ 350 \\ \underline{320} \\ 30 \\ \underline{24} \\ 6 \end{array}$$

### Worksheet 5

1.  $298 + 509 = 807$   
 $807 \times 21 = 16,947$   
 They pack 16,947 boxes of pears in 21 days.

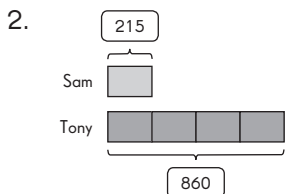

- a. 1 unit  $\rightarrow$  215  
 4 units  $\rightarrow$   $215 \times 4 = 860$   
 Tony has 860 marbles.
- b.  $860 \div 9 = 95 \text{ R } 5$   
 He has 95 full boxes.  
 c. 5 marbles are not packed in a full box.

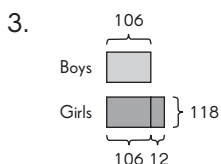

- a. Number of girls  
 $= 106 + 12 = 118$   
 Number of boys and girls  
 $= 106 + 118 = 224$   
 There are 224 students in the school.

- b.  $224 \div 8 = 28$   
 There are 28 students in each class.

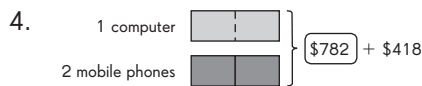

- a.  $\$782 + \$418 = \$1,200$   
 The total cost of all the items is \$1,200.
- b. 4 units  $\rightarrow$  \$1,200  
 2 units  $\rightarrow$   $\$1,200 \div 2 = \$600$   
 The computer costs \$600.



- a.  $\$2,750 - \$262 = \$2,488$   
 The total cost is \$2,488.
- b. 8 units  $\rightarrow$  \$2,488  
 1 unit  $\rightarrow$   $\$2,488 \div 8 = \$311$   
 The cost of each chair is \$311.  
 $\$311 \times 5 = \$1,555$   
 The 5 chairs cost \$1,555.

## Chapter 4

### Worksheet 1

1.  $2,374 - 1,470 = 904$   
 2.  $4,000 - 1,720 = 2,280$   
 3. a  
 4. // 5. /  
 6. ~~||||~~ 7. ///  
 8.

Type of Pet	Dog	Cat	Hamster	Fish	Others
Number	5	2	1	9	3

9. 7 groups of 5 = 35  
 $35 + 1 = 36$
10. cows
11.  $36 - 12 = 24$
12.  $18 + 3 + 36 + 12 = 69$
- 13.

Sport	Tally	Number of Students
Basketball	///	3
Volleyball	//	2
Cycling	//	2
Soccer	/	1

14.

Number Shown	One	Two	Three	Four	Five	Six
Number of times tossed	4	3	2	3	4	3

$4 + 3 + 2 + 3 + 4 + 3 = 19$   
The number cube was tossed 19 times.

15.

Country	USA	France	Kenya	Singapore	Russia
Number of Participants	12	20	15	8	5

$12 + 20 + 15 + 8 + 5 = 60$

16.

Favorite Fruit	Tally	Number of Students
apple		8
pear		7
orange		5
apricot		4
plum		2

17. January

18. May

19.  $8 \text{ cm} - 5 \text{ cm} = \underline{3 \text{ cm}}$

20. April, June

21.  $8 + 6 + 5 + 3 + 2 + 3 = \underline{27 \text{ cm}}$

22. February

23.

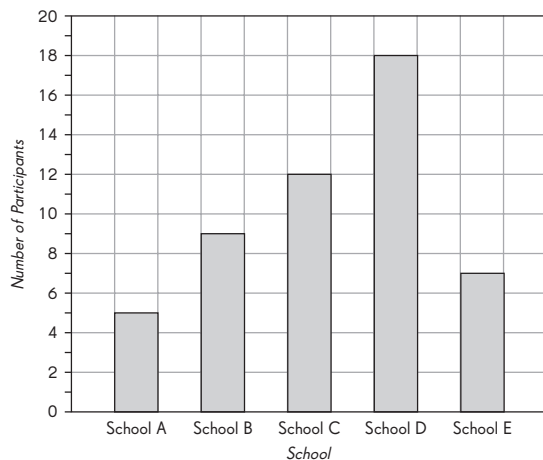

24. dolls

25.  $24 - 6 = 18$

18 more dolls than monkeys were sold.

26.  $14 - 8 = 6$

6 fewer airplanes than dolphins were sold.

27.  $24 - 18 = 6$

6 more cars must be sold to equal the number of dolls sold.

28.  $14 + 6 + 18 + 24 + 8 = 70$

A total of 70 toys were sold during the month of March.

### Worksheet 2

1. W77, P88, Q10

2. T48, S27, P88

3. T48

4. S27 or Y32

5. guavas

6.  $34 - 15 = \underline{19}$

7.  $14 - 9 = \underline{5}$

8. apples

9.  $20 + 8 + 9 + 21 + 4 = \underline{62}$

10.  $200 - 173 = \underline{27}$

11.

Mode of Transportation	Bus	Taxi	Walk	Cycle
Number of Students	76	1	54	42

12. Taxi

13.  $76 + 42 = \underline{118}$

14.  $54 - 42 = \underline{12}$

Day	Number of Green Apples	Number of Red Apples	Total Number of Apples
Monday	60	20	80
Tuesday	15	50	65
Wednesday	30	70	100
Thursday	50	70	120
Friday	40	195	235
Total	195	405	600

15. Friday

16. Tuesday

17. Red apples

18. Monday

19.  $235 - 65 = \underline{170}$

### Worksheet 3

1.  $450 \text{ cents} = \underline{\$4.50}$

2.  $375 \div 75 = 5$

Jerry buys 5 mangoes.

3. 1,000

4.  $4,000 - 1,000 = \underline{3,000}$  liters

5. a. Friday, Saturday

b.  $4,000 - 2,000 = \underline{2,000}$  liters



6.  $5,000 - 1,000 = 4,000$  liters  
The family uses 4,000 liters of water from Monday through Sunday.  
 $4,000 \div 4 = 1,000$  liters  
Each family member uses 1,000 liters of water.
7. 40 grams                      8. 50 grams
9. 15 centimeters              10. 30 centimeters

## Chapter 5

### Worksheet 1

1.  $\frac{48}{5} + \frac{26}{5} + \frac{32}{5} + \frac{57}{5} + \frac{97}{5} = \frac{260}{5}$  mL  
 $\frac{260}{5} = 52$  mL  
The average volume of the containers is 52 milliliters.
2. Total distance =  $\frac{536}{6} + \frac{450}{6} + \frac{152}{6} + \frac{824}{6} + \frac{375}{6} + \frac{459}{6} = \frac{2,796}{6}$  km  
Average distance =  $\frac{2,796}{6} = 466$  km  
The average distance traveled is 466 kilometers.
3. Total volume of milk  
=  $375 \times 8 = 3,000$  mL  
The total volume of milk is 3,000 milliliters.
4.  $\$28 \times 185 = \$5,180$   
She spent \$5,180.
5. Total distance Mary walked in 5 days  
=  $\frac{750}{5} \times 5 = 3,750$  m  
She walked 3,750 meters in 5 days.
6.  $7 \times 68 = 476$  cm  
The total length of their arms is 476 centimeters.
7. a.  $79 \times 4 = 316$   
The total score for the four tests is 316.  
b.  $67 + 74 + 92 = 233$   
 $316 - 233 = 83$   
Joe's score for the third test is 83.
8. Washington
9.  $10 + 9 + 13 + 11 + 15 = 58$  games
10.  $58 \div 2 = 29$  games
11.  $\$8 + \$7 + \$3 = \$18$   
He paid \$18 altogether.
12.  $\$18 \div 3 = \$6$   
The average price of a kilogram of nuts is \$6.

### Worksheet 2

1. a. 802                      b. 802
2. 90                          3. 60
4. a. 111, 113

b. Mean =  $\frac{111 + 113}{2} = \frac{224}{2} = 112$  m

The median is 112 meters.

5. 74 cm, 86 cm, 98 cm, 102 cm, 110 cm, 124 cm

Mean =  $\frac{98 + 102}{2} = \frac{200}{2} = 100$  cm

The median height is 100 centimeters.

6. a. 1                      b. 1                      c. 20

7. a.

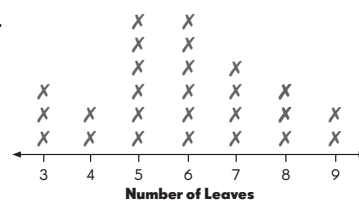

- b. 4                      c. 5, 6

8. a. 7 kg                      b. 12 kg

c. The range of mass lifted  
=  $\frac{12 \text{ kg} - 7 \text{ kg}}{2}$   
= 5 kg

9. 2 ribbons have a length of 12 cm  $\rightarrow 2 \times 12 = 24$  cm  
4 ribbons have a length of 20 cm  $\rightarrow 4 \times 20 = 80$  cm  
2 ribbons have a length of 28 cm  $\rightarrow 2 \times 28 = 56$  cm  
Total length of all the ribbons =  $24 + 80 + 56 = 160$  cm

Mean =  $\frac{160}{8} = 20$  cm

The mean length of the ribbons is 20 centimeters.

- 10.

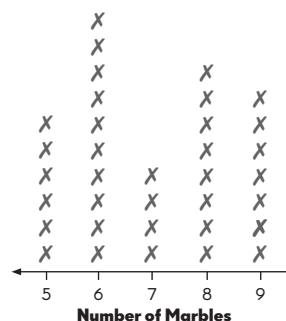

6 bags has 5 marbles each  $\rightarrow 6 \times 5 = 30$   
10 bags have 6 marbles each  $\rightarrow 10 \times 6 = 60$   
4 bags have 7 marbles each  $\rightarrow 4 \times 7 = 28$   
8 bags have 8 marbles each  $\rightarrow 8 \times 8 = 64$   
7 bags have 9 marbles each  $\rightarrow 7 \times 9 = 63$   
Total number of marbles  
=  $30 + 60 + 28 + 64 + 63 = 245$

Mean =  $\frac{245}{35} = 7$

The mean number of marbles is 7.

11.  $7 - 2 = 5$   
The range of the number of people living in the houses is 5.
12. 3                                  13. 1
14. Total number of people  
 $= 3 \times 2 + 5 \times 3 + 5 \times 4 + 4 \times 5 + 2 \times 6 + 1 \times 7 = 80$   
 Total number of houses  
 $= 3 + 5 + 5 + 4 + 2 + 1 = 20$   
 Mean  $= \frac{80}{20} = 4$   
 The mean of the number of people living in each house is 4.
15. The modes are 3 and 4.

### Worksheet 3

1. 42                                  2. 3
3. 24, 27, 34, 41, 45, 47, 48, 52, 58, 63

4.

Number of Rolls	
Stem	Leaves
2	4 7
3	4
4	1 5 7 8
5	2 8
6	3

5. a. 1                                  b. 24  
 c. 63                                  d. 10
6. a. 46, 53, 58  
 b. Range  $= 96 \text{ lb} - 32 \text{ lb} = 64 \text{ lb}$   
 c. 96 pounds
7. a. 42      b. 34      c. 65      d. 21  
 e.  $65 - 21 = 44 \text{ cm}$   
 The range of the lengths is 44 centimeters.
- f. Median  $= \frac{42 + 44}{2} = 43 \text{ cm}$   
 The median length of the snakes is 43 centimeters.

8. a.

Amount of Money	
Stem	Leaves
4	2 6
5	9
6	0 4 5 8
7	5 9

- b. There is no mode as all the amounts appear the same number of times.
- c. Range  $= \$79 - \$42 = \$37$   
 The range of the amount of money collected is \$37.
- d. The middle number is 64. So, the median amount of money collected is \$64.
- e.  $\$42 + \$46 + \$59 + \$60 + \$64 + \$65 + \$68 + \$75 + \$79 = \$558$   
 A total of \$558 was collected.
- f.  $\frac{\$558}{9} = \$62$   
 The average amount of money collected by each stall is \$62.

### Worksheet 4

1. more likely                          2. equally likely
3. a. more likely                      b. less likely
4. a. certain                              b. impossible
5. yellow or green; equally likely
6. green or yellow; less likely
7. green; impossible
8. a    9. b    10. a

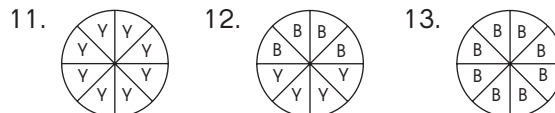

### Worksheet 5

1. Odd numbers: 1, 3, 5  
 Number of favorable outcomes = 3  
 Probability of landing on an odd number  
 $= \frac{3}{6} = \frac{1}{2}$   
 The probability of landing on an odd number is  $\frac{1}{2}$ .
2. Numbers less than 5: 1, 2, 3, 4  
 Number of favorable outcomes = 4  
 Number of possible outcomes = 6  
 Probability of landing on a number less than 5  
 $= \frac{4}{6} = \frac{2}{3}$   
 The probability of landing on a number less than 5 is  $\frac{2}{3}$ .
3. Number more than 3: 4, 5, 6  
 Number of favorable outcomes = 3  
 Number of possible outcomes = 6  
 Probability of landing on a number greater than 3  
 $= \frac{3}{6} = \frac{1}{2}$

The probability of landing on a number greater than 3 is  $\frac{1}{2}$ .

4.  $\frac{5}{10} = \frac{1}{2}$ ; equally likely
5.  $\frac{2}{10} = \frac{1}{5}$ ; less likely
6.  $\frac{7}{10}$ ; more likely
7.  $\frac{0}{10} = 0$ ; impossible
8.  $\frac{2}{10} = \frac{1}{5}$ ; less likely
9.  $\frac{7}{10}$ ; more likely
10.  $\frac{5}{10} = \frac{1}{2}$ ; equally likely
11.  $\frac{10}{10} = 1$ ; certain
12.  $\frac{0}{10} = 0$ ; impossible

### Worksheet 6

1. Total income of 4 workers  
 $= 4 \times \$1,250 = \$5,000$   
 Income of 3 workers =  $\$3,420$   
 Income of the 4<sup>th</sup> worker  
 $= \$5,000 - \$3,420 = \$1,580$   
 The income of the 4<sup>th</sup> worker is  $\$1,580$ .
2. Cost of 3 toys =  $3 \times \$40 = \$120$   
 Cost of 5 toys =  $5 \times \$50 = \$250$   
 Cost of 8 toys =  $\$120 + \$250 = \$370$   
 Cost of the remaining 2 toys  
 $= \$780 - \$370 = \$410$   

$$\text{Mean cost of the 2 toys} = \frac{\$410}{2} = \$205$$
 The mean cost of the remaining 2 toys is  $\$205$ .
3. Total mass of the goat and sheep  
 $= 2 \times 78 \text{ kg} = 156 \text{ kg}$   
 2 units  $\rightarrow$  Total mass =  $6 \text{ kg}$   

$$\frac{156 \text{ kg} - 6 \text{ kg}}{2} = 75 \text{ kg}$$
 1 unit  $\rightarrow$   $\frac{150}{2} = 75 \text{ kg}$   
 The mass of the goat is  $75$  kilograms.  
 $75 \text{ kg} + 6 \text{ kg} = 81 \text{ kg}$   
 The mass of the sheep is  $81$  kilograms.
4. a. Number of roses delivered to 5 florists  
 $= 108 + 156 + 96 + 120 + 84 = 564$   
 Number of roses delivered to Florist F  
 $= \text{Total number of roses} - 564$   
 $= 684 - 564 = 120$   
 The number of roses he delivered to Florist F is  $120$ .  
 b. Range =  $156 - 84 = 72$   
 The range of the number of roses delivered is  $72$ .  
 c.  $120$

- d. The numbers ordered from least to greatest:  
 $84, 96, 108, 120, 120, 156$   
 The middle numbers are  $108$  and  $120$ .

$$\text{Mean} = \frac{108 + 120}{2} = 114$$

The median of the set of data is  $114$ .

5. a. Longest distance =  $8 \text{ m} + 66 \text{ m} = 74 \text{ m}$   
 The longest distance the javelin was thrown is  $74$  meters.  
 b. Total distance =  $70 \text{ m} \times 5 = 350 \text{ m}$   
 The missing data  
 $= 350 \text{ m} - 68 \text{ m} - 72 \text{ m} - 66 \text{ m} - 74 \text{ m}$   
 $= 70 \text{ m}$   
 The missing data is  $70$  meters.  
 c. The distances ordered from least to greatest:  
 $66, 68, 70, 72, 74$   
 The median distance is  $70$  meters.
6. a. Total amount - Amount of money deposited in 11 months  
 $= \$960 - \$63 - \$66 - \$68 - \$72 - \$80 - \$84 - \$84 - \$89 - \$91 - \$92 - \$97$   
 $= \$74$   
 The missing data in stem 7 is  $\$74$ .  
 b.  $\$84$   
 c. Mean =  $\frac{\$80 + \$84}{2} = \$82$   
 The median of the set of data is  $\$82$ .  
 d.  $\$97 - \$63 = \$34$
7. a. 6  
 b. 6  
 c.  $1 \times 3 \text{ lb} = 3 \text{ lb}$   
 $2 \times 4 \text{ lb} = 8 \text{ lb}$   
 $3 \times 5 \text{ lb} = 15 \text{ lb}$   
 $5 \times 6 \text{ lb} = 30 \text{ lb}$   
 $4 \times 7 \text{ lb} = 28 \text{ lb}$   
 $3 \times 8 \text{ lb} = 24 \text{ lb}$   
 $2 \times 9 \text{ lb} = 18 \text{ lb}$   
 Total weight =  $3 + 8 + 15 + 30 + 28 + 24 + 18 = 126 \text{ lb}$   
 Total cost =  $\$3 \times 126 = \$378$   
 The total cost of all the watermelons is  $\$378$ .
8. a. i. less likely  
 ii. less likely  
 iii. more likely  
 iv. certain  
 b. i. Number of favorable outcomes =  $6$   
 Number of possible outcomes  
 $= 16 + 1 + 3 = 20$   
 Probability of drawing a red marble  
 $= \frac{6}{20} = \frac{3}{10}$

The probability that a red marble is drawn is  $\frac{3}{10}$ .

- ii. Number of favorable outcomes =  $\underline{18}$   
 Number of possible outcomes =  $\underline{20}$   
 Probability of drawing a red, blue, or green marble =  $\frac{18}{20} = \frac{9}{10}$   
 The probability that Tyron draws a red, blue, or green marble is  $\frac{9}{10}$ .

### Chapter 6

#### Worksheet 1

1.  $\frac{4}{8}$  

2.  $\frac{9}{15}$  

3.  $\frac{3}{4}$                       4.  $\times 5; \frac{35}{45}$

5.  $\frac{4}{6}; \times 4$                       6.  $\times 6; \times 6$

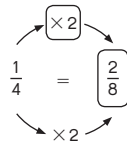
7.  $\frac{1}{4} = \frac{2}{8}$  

$\frac{3}{8} + \frac{1}{4} = \frac{3}{8} + \frac{2}{8} = \frac{5}{8}$

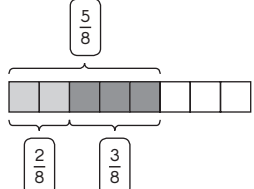

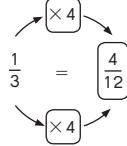
8.  $\frac{1}{3} = \frac{4}{12}$  

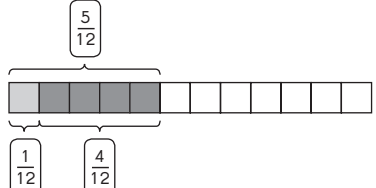

$\frac{1}{12} + \frac{1}{3} = \frac{1}{12} + \frac{4}{12} = \frac{5}{12}$

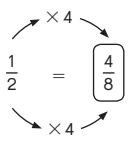
9.  $\frac{1}{2} = \frac{4}{8}$  

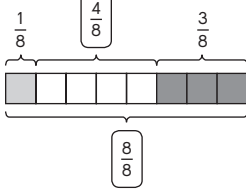

$\frac{1}{8} + \frac{1}{2} + \frac{3}{8} = \frac{1}{8} + \frac{4}{8} + \frac{3}{8}$

$= \frac{8}{8} = 1$

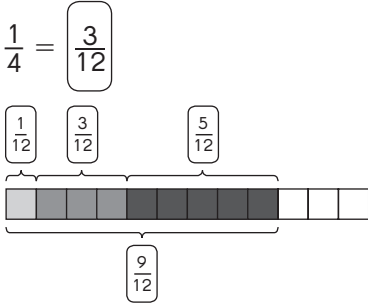
10.  $\frac{1}{4} = \frac{3}{12}$  

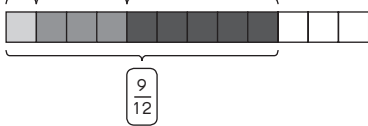

$\frac{1}{12} + \frac{1}{4} + \frac{5}{12} = \frac{1}{12} + \frac{3}{12} + \frac{5}{12}$

$= \frac{9}{12} = \frac{3}{4}$

11.  $\frac{6}{17}$

12.  $\frac{3}{7}$

13.  $\frac{1}{3}$

14.  $\frac{5}{7}$

15.  $\frac{6}{9} = \frac{2}{3}$

16.  $\frac{12}{12} = 1$

17.  $\frac{3}{10} + \frac{2}{5} + \frac{1}{10} = \frac{3}{10} + \frac{4}{10} + \frac{1}{10}$

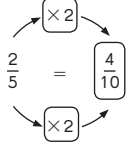
$= \frac{8}{10} = \frac{4}{5}$  

$$18. \frac{1}{4} + \frac{1}{6} + \frac{5}{12}$$

$$= \frac{3}{12} + \frac{2}{12} + \frac{5}{12}$$

$$= \frac{10}{12} = \frac{5}{6}$$

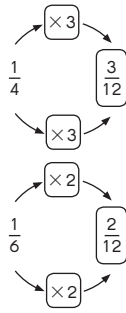

$$9. \frac{7}{12} - \frac{1}{4} = \frac{7}{12} - \frac{3}{12}$$

$$= \frac{4}{12} = \frac{1}{3}$$

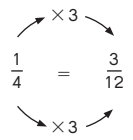

$$10. \frac{11}{12} - \frac{1}{6} = \frac{11}{12} - \frac{2}{12}$$

$$= \frac{9}{12} = \frac{3}{4}$$

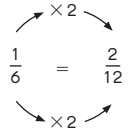

### Worksheet 2

$$1. \frac{6}{8}$$

$$2. \frac{4}{10}$$

$$3. \frac{2}{8} = \frac{1}{4}$$

$$4. \frac{2}{10} = \frac{1}{5}$$

$$5. \frac{3}{12} = \frac{1}{4}$$

$$6. \frac{3}{4} = \frac{9}{12}$$

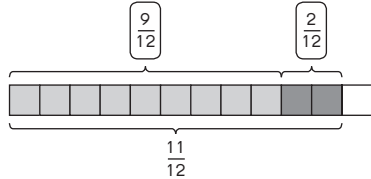

$$\frac{11}{12} - \frac{3}{4} = \frac{11}{12} - \frac{9}{12} = \frac{2}{12} = \frac{1}{6}$$

$$7. 1 = \frac{9}{9}$$

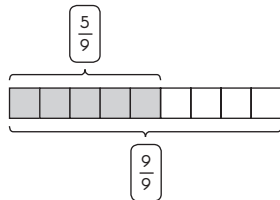

$$1 - \frac{5}{9} = \frac{9}{9} - \frac{5}{9} = \frac{4}{9}$$

$$8. 1 - \frac{7}{10} = \frac{10}{10} - \frac{7}{10} = \frac{3}{10}$$

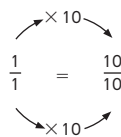

$$11. 1 - \frac{4}{12} - \frac{1}{4} = \frac{12}{12} - \frac{4}{12} - \frac{3}{12}$$

$$= \frac{5}{12}$$

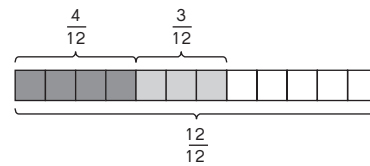
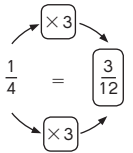

$$12. 1 - \frac{2}{10} - \frac{3}{5} = \frac{10}{10} - \frac{2}{10} - \frac{6}{10}$$

$$= \frac{2}{10} = \frac{1}{5}$$

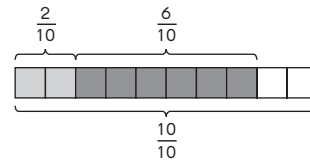
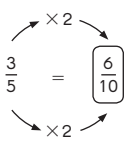

$$13. \frac{17}{21} - \frac{2}{3} = \frac{17}{21} - \frac{14}{21}$$

$$= \frac{3}{21} = \frac{1}{7}$$

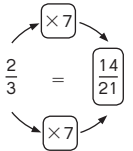

$$14. 1 - \frac{1}{4} - \frac{5}{12} = \frac{12}{12} - \frac{3}{12} - \frac{5}{12}$$

$$= \frac{4}{12} = \frac{1}{3}$$

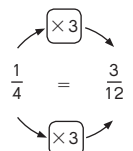

$$15. 1 - \frac{1}{4} - \frac{3}{20} = \frac{20}{20} - \frac{5}{20} - \frac{3}{20}$$

$$= \frac{12}{20} = \frac{3}{5}$$

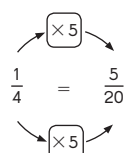

### Worksheet 3

1.  $1 + \frac{3}{8} = 1\frac{3}{8}$       2.  $2 + \frac{3}{5} = 2\frac{3}{5}$



3.  $3 + \frac{3}{5} = 3\frac{3}{5}$       4.  $2 + \frac{7}{12} = 2\frac{7}{12}$

Exercises 5, 6 and 7:

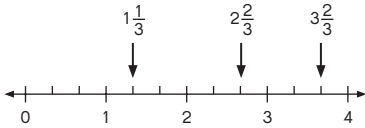

8.  $2\frac{1}{4}$       9.  $3\frac{3}{4}$

10.  $1 + \frac{6}{8} = 1\frac{6}{8} = 1\frac{3}{4}$

11.  $2 + \frac{8}{14} = 2\frac{8}{14} = 2\frac{4}{7}$

### Worksheet 4

1.  $\frac{3}{4}$       2.  $\frac{4}{5}$
3.  $\frac{5}{6}$       4.  $\frac{6}{8}$
5.  $\frac{7}{10}$
6. 4; 1; 5;  
 $2\frac{1}{2} = \frac{1}{2} + \frac{1}{2} + \frac{1}{2} + \frac{1}{2} + \frac{1}{2} = \frac{5}{2}$
7. 4; 3; 7;  
 $1\frac{3}{4} = \frac{1}{4} + \frac{1}{4} + \frac{1}{4} + \frac{1}{4} + \frac{1}{4} + \frac{1}{4} + \frac{1}{4} = \frac{7}{4}$
8. 11; 11;  $\frac{11}{6}$       9. 29; 29;  $\frac{29}{8}$
10.  $\frac{3}{2}$       11.  $\frac{8}{5}$
12.  $\frac{15}{4}$       13.  $\frac{4}{3}$

Exercises 14, 15 and 16:

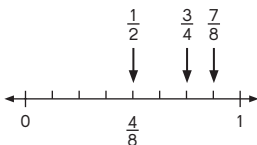

17.  $\frac{4}{4}, \frac{6}{4}, \frac{9}{4}, \frac{11}{4}, \frac{12}{4}$       18.  $\frac{9}{8}, \frac{10}{8}, \frac{12}{8}, \frac{13}{8}, \frac{15}{8}$

### Worksheet 5

1. 1      2. 1
3. 6      4. 7
5. 8
6.  $\frac{14}{5} = 14 \text{ fifths} = 10 \text{ fifths} + 4 \text{ fifths}$   
 $= \frac{10}{5} + \frac{4}{5} = 2\frac{4}{5}$
7.  $\frac{23}{6} = 23 \text{ sixths} = 18 \text{ sixths} + 5 \text{ sixths}$   
 $= \frac{18}{6} + \frac{5}{6} = 3\frac{5}{6}$
8. 2; 2      9. 5; 2

$$\begin{array}{r} 3 \overline{)8} \\ \underline{6} \\ 2 \end{array} \qquad \begin{array}{r} 7 \overline{)37} \\ \underline{35} \\ 2 \end{array}$$

$$\frac{8}{3} = 2\frac{2}{3} \qquad \frac{37}{7} = 5\frac{2}{7}$$

10.  $\frac{26}{4} = 26 \text{ quarters}$   
 $= 24 \text{ quarters} + 2 \text{ quarters}$

$= \frac{24}{4} + \frac{2}{4}$       **Check**  
 $= 6 + \frac{2}{4}$        $\begin{array}{r} 6 \\ 4 \overline{)26} \\ \underline{24} \\ 2 \end{array} \quad 26 \div 4 = 6 \text{ R } 2$   
 $= 6 + \frac{1}{2} = 6\frac{1}{2}$        $\frac{26}{4} = 6\frac{2}{4} = 6\frac{1}{2}$

11.  $\frac{48}{9} = 48 \text{ ninths}$   
 $= 45 \text{ ninths} + 3 \text{ ninths}$

$= \frac{45}{9} + \frac{3}{9}$       **Check**  
 $= 5 + \frac{3}{9}$        $\begin{array}{r} 5 \\ 9 \overline{)48} \\ \underline{45} \\ 3 \end{array} \quad 48 \div 9 = 5 \text{ R } 3$   
 $= 5 + \frac{1}{3} = 5\frac{1}{3}$        $\frac{48}{9} = 5\frac{3}{9} = 5\frac{1}{3}$

12.  $4\frac{1}{3} = 4 + \frac{1}{3} = \frac{12}{3} + \frac{1}{3} = \frac{13}{3}$        $\frac{4}{1} = \frac{12}{3}$

$$13. 6\frac{2}{5} = 6 + \frac{2}{5}$$

$$= \frac{30}{5} + \frac{2}{5} = \frac{32}{5}$$

$$14. 5\frac{1}{2} = 5 + \frac{1}{2}$$

$$= \frac{10}{2} + \frac{1}{2}$$

$$= \frac{11}{2}$$

**Check**

 $5 \times 2 = 10$   
 $10 + 1 = 11$   
 There are 11 halves in  $5\frac{1}{2}$ .

$$15. 7\frac{5}{6} = 7 + \frac{5}{6}$$

$$= \frac{42}{6} + \frac{5}{6}$$

$$= \frac{47}{6}$$

**Check**

 $7 \times 6 = 42$   
 $42 + 5 = 47$   
 There are 47 sixths in  $7\frac{5}{6}$ .

$$16. 8\frac{8}{9} = 8 + \frac{8}{9}$$

$$= \frac{72}{9} + \frac{8}{9}$$

$$= \frac{80}{9}$$

**Check**

 $8 \times 9 = 72$   
 $72 + 8 = 80$   
 There are 80 ninths in  $8\frac{8}{9}$ .

### Worksheet 6

$$1. \frac{4}{5} + \frac{3}{5} = \frac{7}{5} = \frac{5}{5} + \frac{2}{5} = 1 + \frac{2}{5}$$

$$= 1\frac{2}{5}$$

$$2. \frac{7}{12} + \frac{11}{12} = \frac{18}{12} = \frac{12}{12} + \frac{6}{12}$$

$$= 1 + \frac{6}{12}$$

$$= 1\frac{6}{12} = 1\frac{1}{2}$$

$$3. \frac{4}{5} + \frac{7}{10} = \frac{8}{10} + \frac{7}{10} = \frac{15}{10} = \frac{3}{2} = 1\frac{1}{2}$$

$$4. \frac{8}{9} + \frac{1}{3} = \frac{8}{9} + \frac{3}{9} = \frac{11}{9} = 1\frac{2}{9}$$

$$5. \frac{2}{3} + \frac{7}{12} + \frac{11}{12} = \frac{8}{12} + \frac{7}{12} + \frac{11}{12}$$

$$= \frac{26}{12} = \frac{13}{6} = 2\frac{1}{6}$$

$$6. 1 + \frac{3}{4} + \frac{7}{12} = \frac{12}{12} + \frac{9}{12} + \frac{7}{12}$$

$$= \frac{28}{12} = \frac{7}{3} = 2\frac{1}{3}$$

$$7. 3 = 2\frac{8}{8}$$

$$8. 4 = 3\frac{12}{12}$$

$$9. 2 = 1\frac{5}{5}$$

$$10. 5 = 4\frac{4}{4}$$

$$11. 1 - \frac{3}{8} = \frac{8}{8} - \frac{3}{8} = \frac{5}{8}$$

$$12. 3 - \frac{5}{12} = 2\frac{12}{12} - \frac{5}{12} = 2\frac{7}{12}$$

$$13. 3 - \frac{5}{9} = \frac{27}{9} - \frac{5}{9} = \frac{22}{9} = 2\frac{4}{9}$$

$$14. 4 - \frac{2}{3} = \frac{12}{3} - \frac{2}{3} = \frac{10}{3} = 3\frac{1}{3}$$

$$15. \frac{3}{4} - \frac{7}{12} = \frac{9}{12} - \frac{7}{12} = \frac{2}{12} = \frac{1}{6}$$

$$16. \frac{5}{6} - \frac{5}{12} = \frac{10}{12} - \frac{5}{12} = \frac{5}{12}$$

$$17. \frac{4}{5} - \frac{3}{10} = \frac{8}{10} - \frac{3}{10} = \frac{5}{10} = \frac{1}{2}$$

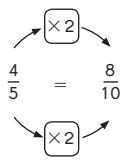

### Worksheet 7

1. 2                                 2. 16  
3. 21                                4. 15  
5. 18                               6. 8; 3

7.  $\frac{3}{8}$

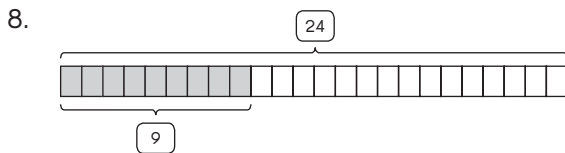

9. 5                                   10. 10

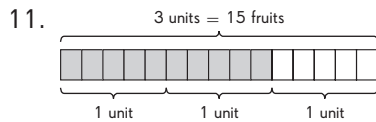

12.  $\frac{10}{15}$  or  $\frac{2}{3}$                    13. 5; 10

14.  $\frac{8}{3}$  units =  $\frac{32}{3}$   
1 unit =  $\frac{32}{3} \div 8 = 4$   
3 units =  $4 \times 3 = 12$   
So,  $\frac{3}{8}$  of 32 =  $\frac{12}{3}$ .

15. 3; 28; 84; 21               16. 2; 56; 7; 112; 7; 16  
17. 24                               18. 28

### Worksheet 8

1.  $\frac{2}{3} + \frac{5}{6} + \frac{5}{6} = \frac{4}{6} + \frac{5}{6} + \frac{5}{6}$   
 $= \frac{14}{6} = \frac{7}{3} = 2\frac{1}{3}$

They bought  $2\frac{1}{3}$  pounds of dried fruit altogether.

2.  $\frac{1}{4} + \frac{7}{12} + \frac{11}{12} = \frac{3}{12} + \frac{7}{12} + \frac{11}{12}$   
 $= \frac{21}{12} = 1\frac{3}{4}$

She used  $1\frac{3}{4}$  kilograms of flour altogether.

3.  $\frac{7}{12} + \frac{3}{4} + \frac{5}{12}$   
 $= \frac{7}{12} + \frac{9}{12} + \frac{5}{12} = \frac{21}{12} = \frac{7}{4} = 1\frac{3}{4}$

The total weight of the fruit salad was  $1\frac{3}{4}$  pounds.

4.  $\frac{1}{3} + \frac{4}{9} = \frac{3}{9} + \frac{4}{9} = \frac{7}{9}$

$1 - \frac{7}{9} = \frac{9}{9} - \frac{7}{9} = \frac{2}{9}$

Sam spent  $\frac{2}{9}$  of his time playing computer games.

5.  $\frac{1}{6} + \frac{1}{3} = \frac{1}{6} + \frac{2}{6} = \frac{3}{6}$

$1 - \frac{3}{6} = \frac{6}{6} - \frac{3}{6} = \frac{3}{6} = \frac{1}{2}$

Latoya kept  $\frac{1}{2}$  of the pizza for her grandmother.

6.  $\frac{7}{8} + \frac{3}{4} = \frac{13}{8}$

$\frac{13}{8} - \frac{3}{8} = \frac{10}{8} = 1\frac{1}{4}$

$1\frac{1}{4}$  liters of mixed juice was left in the jug.

7. a.  $\frac{4}{10}; \frac{4}{10} = \frac{2}{5}$

Elan gives away  $\frac{2}{5}$  of his marbles.

b.  $1 - \frac{2}{5} = \frac{3}{5}$

$\frac{3}{5}$  of the marbles are left.

8.  $\frac{8}{12} = \frac{2}{3}$

She cuts off  $\frac{2}{3}$  of the ribbon.

$1 - \frac{2}{3} = \frac{1}{3}$

$\frac{1}{3}$  of the ribbon is left.



9. **Method 1**

$$7 \text{ units} = \$14$$

$$1 \text{ unit} = \$2$$

$$3 \text{ units} = \$2 \times 3 = \$6$$

$$\$14 - \$6 = \$8$$

Winton had \$8 left.

**Method 2**

$$\frac{3}{7} \text{ of } \$14 = \frac{3}{7} \times \$14$$

$$= \frac{\$42}{7}$$

$$= \$6$$

He spent \$6.

$$\$14 - \$6 = \$8$$

Winton had \$8 left.

10. **Method 1**

$$9 \text{ units} = 621 \text{ m}^2$$

$$1 \text{ unit} = 69 \text{ m}^2$$

$$5 \text{ units} = 69 \text{ m}^2 \times 5 = 345 \text{ m}^2$$

$$621 - 345 = 276 \text{ m}^2$$

He planted tulips on 276 square meters of land.

**Method 2**

$$\frac{5}{9} \text{ of } 621 \text{ m}^2 = \frac{5}{9} \times 621 \text{ m}^2$$

$$= \frac{3,105 \text{ m}^2}{9}$$

$$= 345 \text{ m}^2$$

$$621 - 345 = 276 \text{ m}^2$$

He planted tulips on 276 square meters of land.

11. **Method 1**

$$3 \text{ units} = 156$$

$$1 \text{ unit} = 52$$

$$156 - 52 = 104$$

There are 104 economy-class seats.

**Method 2**

$$\frac{1}{3} \text{ of } 156 = \frac{1}{3} \times 156$$

$$= \frac{156}{3}$$

$$= 52$$

$$156 - 52 = 104$$

There are 104 economy-class seats.

$$12. \frac{1}{8} \times 6 = \frac{6}{8}$$

$$= \frac{3}{4}$$

They eat  $\frac{3}{4}$  of the pear altogether.

$$13. \frac{2}{9} \times 12 = \frac{24}{9}$$

$$= 2\frac{6}{9}$$

$$= 2\frac{2}{3}$$

Mr. Lee prepared  $2\frac{2}{3}$  liters of orange juice altogether.

**Worksheet 9**

1.

Length of Leaves	Tally	Number of Leaves
1 cm	/	1
2 cm	/	1
3 cm	////	4
4 cm		5
5 cm	/	6
6 cm	///	3
7 cm	//	2
8 cm	/	1

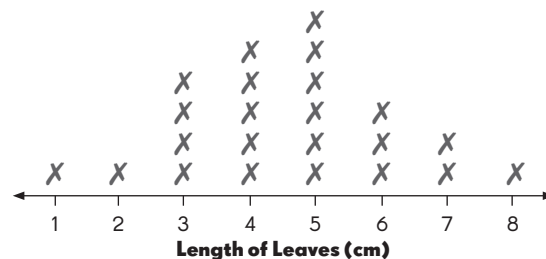

2.

- a. Bus
- b. Answers vary.
- c. Bicycle
- d. Answer vary.
- e.  $4 - 1 = 3$   
3 more children go to school by bus than by bicycle.

